

NEOREST NX Luxurious Integrated Toilet

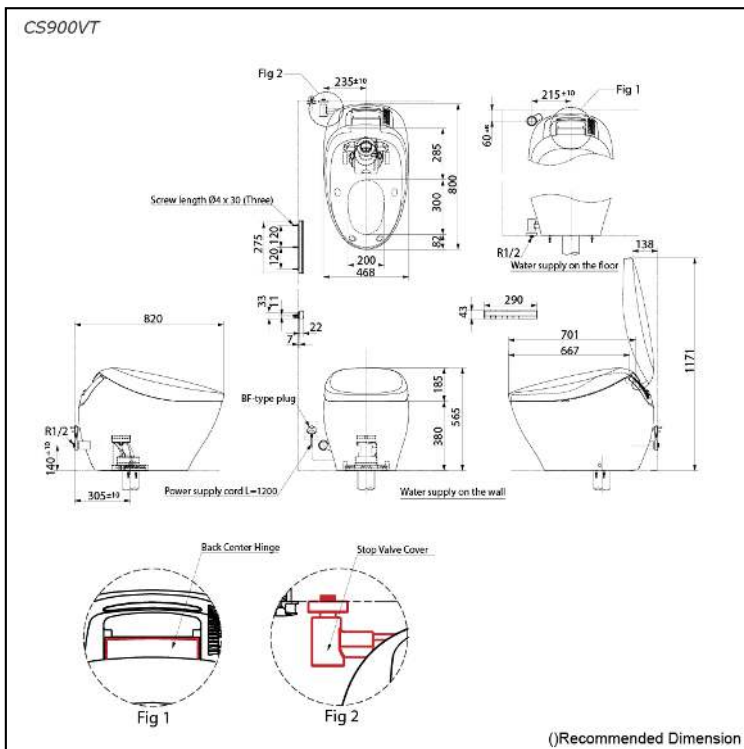

Features

- Integrated appearance of luxury, elegant and seamless design
- Hybrid Ecology System
 - WATER SAVING dual flush 3.8 / 3L
 - Minimum required water pressure only at 0.05MPa (Dynamic)
- HEATED SEAT with temperature control
- PREMIST, a fine spray of mist making it difficult for dirt to adhere
- EWATER+ keeps toilet bowl and nozzle clean by preventing bacteria with sanitizing effect
- Auto powerful DEODORIZER activates after every usage
- Auto Soft light function usable for night time usage
- Adjustable WARM AIR DRYING
- Automatically cleans the wand jet
- AIR-IN WONDERWAVE cleansing provides comfort and eco-friendliness

EWATER+, highly effective sanitizer created by electrolyzed chloride ion in tap water. After use, it returns back to original state, environmental friendly

Specifications

Flush system:	TORNADO FLUSH
Water Use:	3.8L / 3L
Rough-in:	305 mm
Bowl Shape:	Elongated
Water Pressure:	0.05MPa~0.75MPa
Power Rating:	220~240V, 50/60Hz, 835~845W
Length of Power Cord:	1.2 m
Material:	Bowl -Vitreous China Seat & Cover -Plastic Remote Controller -Aluminium
Size:	468Wx800Dx565H mm

Parts description

- CS900VT
Water Closet Bowl (S-Trap)
(Rough-in 305)

Colors

- White (CEFIONTECT)
- Water Closet Bowl
- Silver
- Stop Valve Cover
- Back Center Hinge
- Remote Controller