

### SPECIFICATIONS

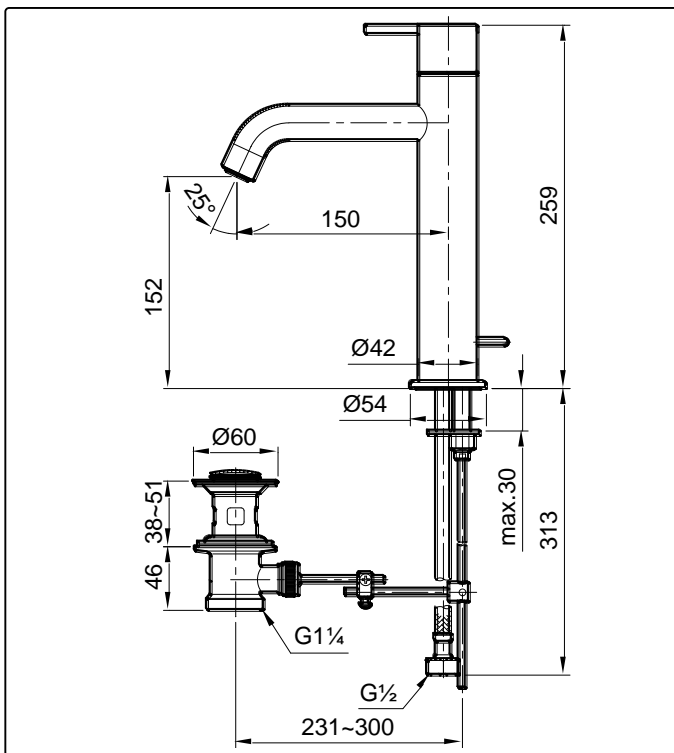

### OPERATING CONDITIONS

1. Water supply pressure : 0.05 ~ 0.75 MPa.
2. Ensure that water supply is clean ( No Sand, Dirt, Etc.).

### MAINTENANCE

Always wipe chrome plated area with dry soft cloth, and sometimes wipe it with cloth soaked in mild soap.

### ATTENTION

1. Don't use abrasive cleaning material such as; detergents containing hydrochloric acids, thinner, polishing powder, and nylon brush.
2. As the product model is constantly updated, the actual product may not look the same as it shown in the diagram, but the basic installation principles are the same.

### INSTALLATION

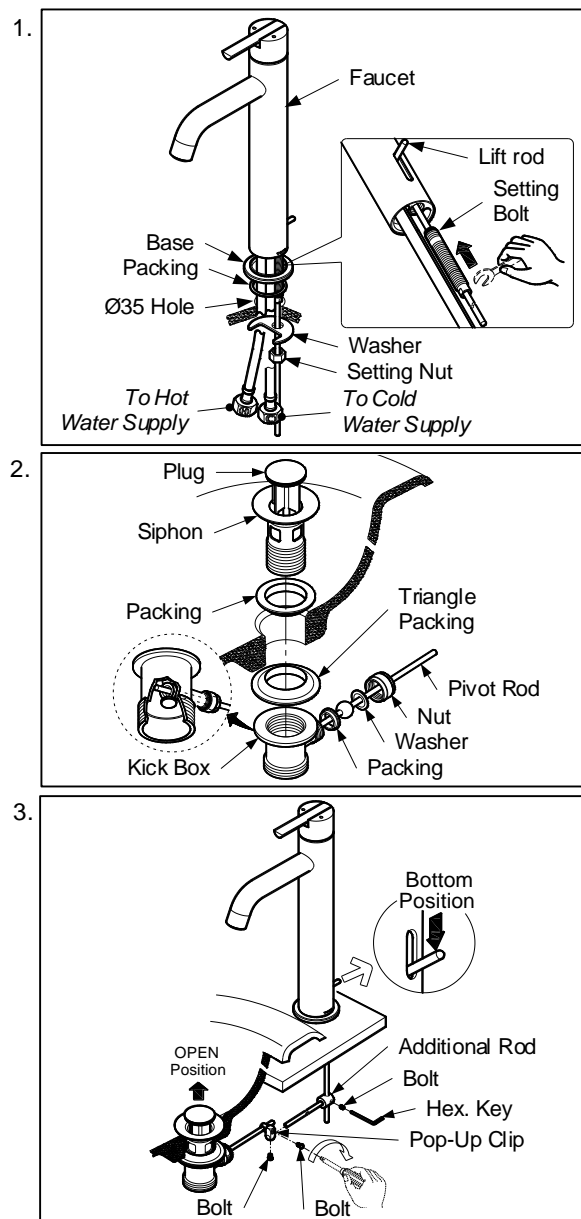

### TROUBLESHOOTING

PROBLEM	CHECK POINT	SOLUTION
Flow rate unsatisfactory	1	Remove and clean
Water leaks around the handle	2	Tighten
Handle is loose	3	Tighten
Plug cannot open and close	4	Tighten
Body swinging	5	Tighten

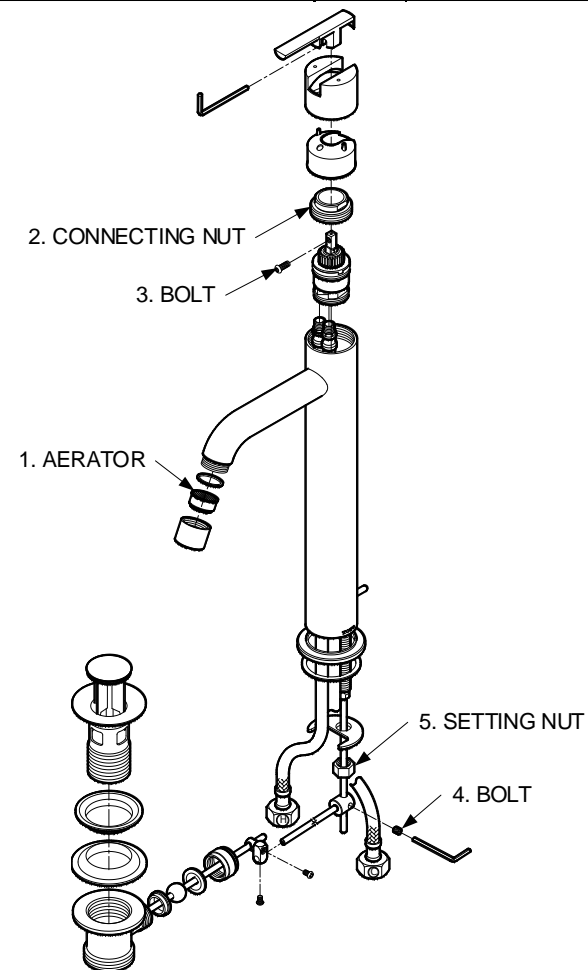

### SPESIFIKASI

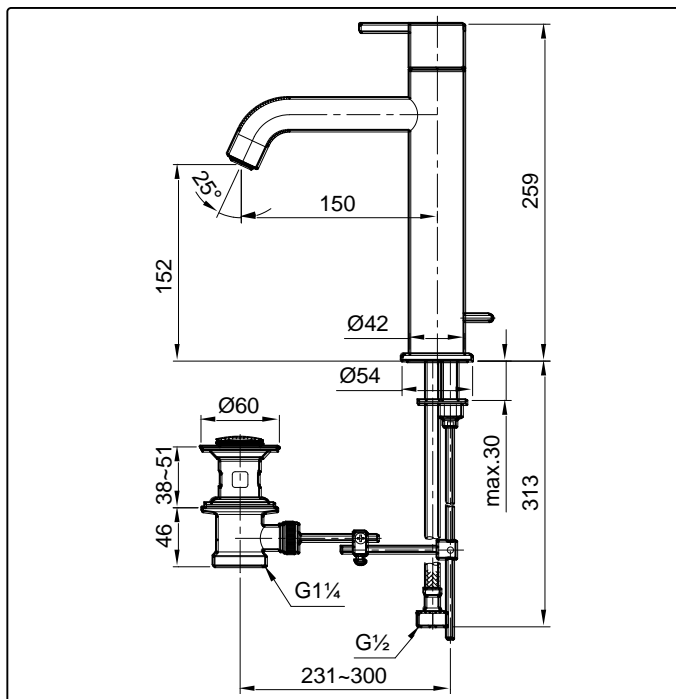

### KONDISI OPERASIONAL

1. Tekanan sumber air: 0.05 ~ 0.75 MPa.
2. Pastikan kondisi sumber air adalah bersih (tidak ada pasir, kotoran dan lain lain)

### PEMELIHARAAN

Selalu bersihkan area yang berlapis krom dengan kain lembut kering, dan sesekali bersihkan dengan kain yang direndam dalam sabun yang dicampur air.

### PERHATIAN

1. Jangan gunakan bahan pembersih yang bersifat abrasif seperti deterjen yang mengandung asam klorida, tinner, bubuk polishing dan sikat nilon.
2. Karena model produk terus mengalami pembaharuan, aktual produk mungkin tidak sama dengan gambar, tapi prinsip dasar pemasangan adalah sama.

### PEMASANGAN

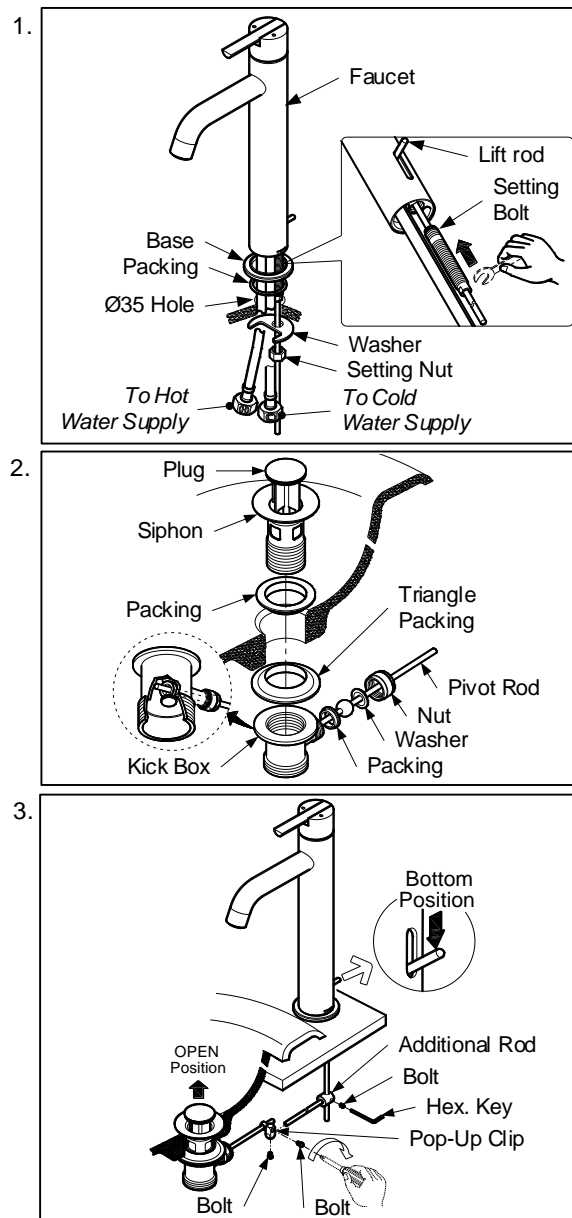

### PENYELESAIAN MASALAH

MASALAH	POIN PERIKSA	SOLUSI
Laju aliran tidak memuaskan	1	Lepas dan bersihkan
Air bocor disekitar handle	2	Kencangkan
Handle longgar	3	Kencangkan
Plug tidak bisa membuka dan menutup	4	Kencangkan
Bodi goyah	5	Kencangkan

